

After recording return document to:

City of Mount Vernon
P.O. Box 809
Mount Vernon, WA 98273



200007140017

Kathy Hill, Skagit County Auditor
7/14/2000 Page 1 of 5 8:57:01AM

Document Title: Temporary Construction Easement
Reference Number of Related Document: N/A
Grantor(s): HP Limited Liability Company
Grantee: The City of Mount Vernon
Legal Description: Ptn. of Sec. 18, T 34 N, R 4 E, W.M.
Additional Legal Description is on: Exhibit "A"
Assessor's Tax Parcel Numbers: 340418-1-005-0108

T-81027
LAND TITLE COMPANY OF SKAGIT COUNTY

In the Matter of: Riverside Bridge Replacement and Alignment Change

EASEMENT DEED AND AGREEMENT

THIS EASEMENT AND AGREEMENT is executed this 29th day of June, 2000, by HP LIMITED LIABILITY COMPANY, A WASHINGTON LIMITED LIABILITY COMPANY, as "Grantors," and THE CITY OF MOUNT VERNON, a municipal corporation of the State of Washington, as "Grantee," over, under, through, across, and upon real property in Skagit County, Washington, legally described in attached Exhibit "A".

WITNESSETH: Grantors, for and in consideration of ONE THOUSAND, FIVE HUNDRED EIGHTY AND 00/100 DOLLARS (\$1,580.00), receipt of which is hereby acknowledged, and the covenants and promises of Grantee hereinafter set forth, hereby grants Grantee a temporary construction easement to facilitate the construction of the Riverside Bridge Replacement and Alignment Change Project.

This temporary construction easement shall include only such rights in the land above described as shall be necessary or convenient for the construction of the Riverside Bridge Replacement and Alignment Change Project. The Grantors, their successors and assigns, shall have the right to use said property in any way and for any purpose not inconsistent with the rights herein granted.

To the extent allowed by law, Grantee agrees to indemnify Grantors from and against any and all claims, demands, suits, damages, or loss, or liability arising from Grantee's exercise of the rights granted herein except for such claims, demands, loss or liability arising out of the negligence of Grantors, or Grantors' employees or agents.

This temporary construction easement shall be binding on the parties, their successors, and assigns, in full force and effect until the Project is constructed and accepted as complete by Grantee, or upon the expiration of two years from the date of this instrument, whichever event occurs first, PROVIDED THAT Grantee, in its sole discretion, may extend this easement for three additional one-year periods upon the payment to Grantor of the SEVEN HUNDRED NINETY AND 00/100 DOLLARS (\$790) for each year that the easement is extended. Such payment for each extension shall be paid over to Grantor on or before the last date of the lease period, or the last case of the preceding extension period, as applicable.

At Grantor's request, Grantee shall execute a release of easement in a standard form, upon the completion of the Project or upon the termination of this easement and any extensions thereto as provided for herein.

GRANTORS:

**HP LIMITED LIABILITY COMPANY,
A WASHINGTON LIMITED LIABILITY COMPANY**

By: <u>George B. Eusterman</u>	By: <u>Louise Eusterman</u>
Dated: <u>6-29-00</u>	Dated: <u>6-29-00</u>
Name: <u>GEORGE B. EUSTERMAN</u>	Name: <u>LOUISE EUSTERMAN</u>
Title: <u>Manager HP LLC</u>	Title: <u>MANAGER HPLLC</u>

STATE OF WASHINGTON)
) §
COUNTY OF SKAGIT)

I certify that I know or have satisfactory evidence that George B Eusterman and Louise Eusterman signed this instrument, on oath stated that (he/she/they) (was/were) authorized to execute the instrument and acknowledged it as the manager(s) of HP Limited Liability Company to be the free and voluntary act of such party for the uses and purposes mentioned in the instrument.

Dated: June 29, 2000
 Notary Signature: Jay R Larson
 Notary Public in and for the State of Washington
 Notary (print name): Jay R. Larson
 Residing at: Bainbridge Rd,
 My appointment expires: 12-27-2000



APPROVED AS TO FORM:

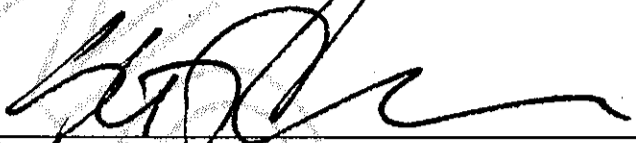

Scott Thomas
City Attorney of Mount Vernon

Mayor Pro-tem

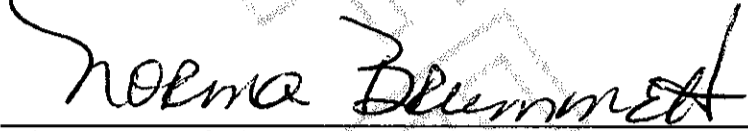

Skye K. Richendrfer
Mayor of Mount Vernon

36258
SKAGIT COUNTY WASHINGTON
Real Estate Excise Tax
PAID

JUL 14 2000

Amount Paid \$ 0
Skagit County Treasurer
By: DC Deputy

Attest:



Mark Knowles
Finance Director of Mount Vernon



200007140017
Kathy Hill, Skagit County Auditor
7/14/2000 Page 3 of 5 8:57:01AM

EXHIBIT "A"

LEGAL DESCRIPTION FOR: Construction Easement - Parcel No. P-26228, HP Limited Liability Company

That portion of the Northeast Quarter of Section 18, Township 34 North, Range 4 East, W.M., described as follows:

Beginning at the Northeast corner of the East 160 feet of that portion of the South Quarter of the North half of the Northeast Quarter of the Northeast Quarter of said Section 18, lying West of the State Highway right-of-way as conveyed to the State of Washington by deed dated June 30, 1937, recorded December 3, 1937 in Volume 173 of deeds, page 390; thence North $88^{\circ} 19' 45''$ West along the North line thereof a distance of 10.50 feet; thence South $1^{\circ} 01' 14''$ West 52.38 feet; thence South $88^{\circ} 58' 46''$ East, 10.5 feet to the West line of said highway right-of-way; thence North $1^{\circ} 01' 14''$ East 52.26 feet to the point of beginning.

See attached Exhibit "A".



200007140017

Kathy Hill, Skagit County Auditor

EXHIBIT A

T.34 N. R.4 E.WM

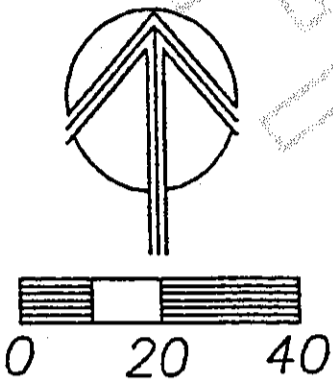
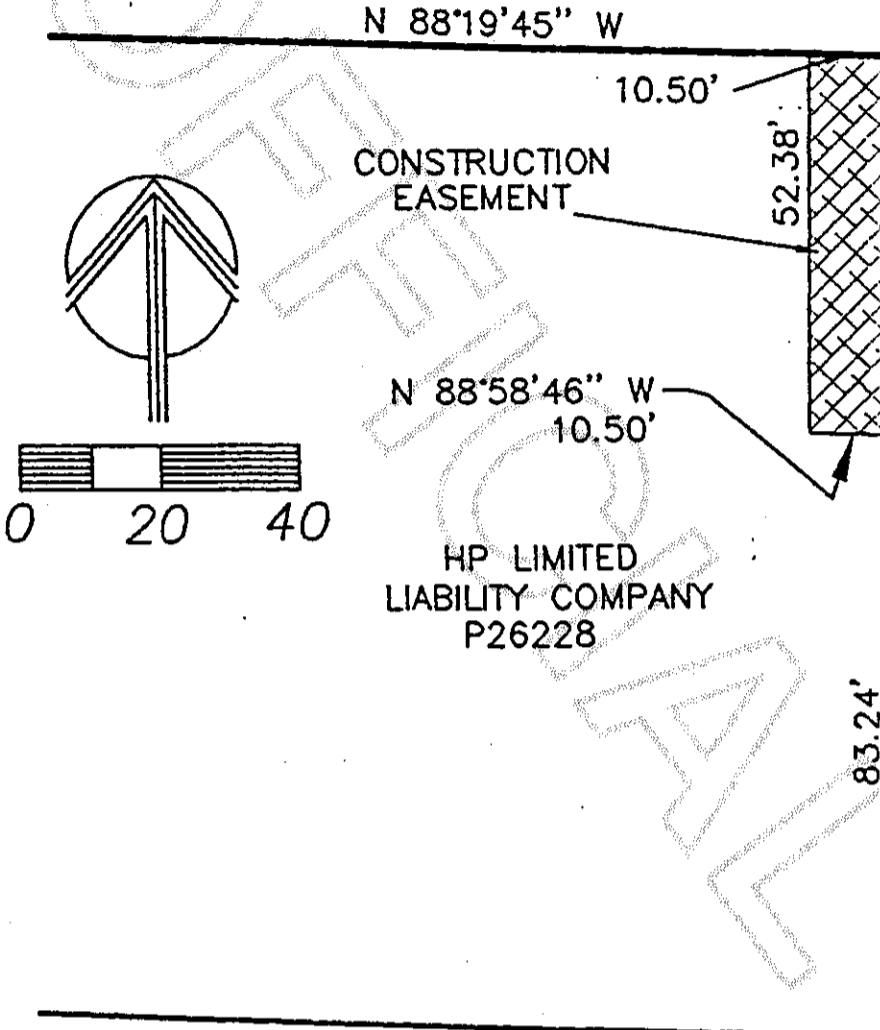
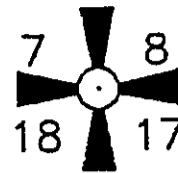

CONSTRUCTION EASEMENT

N 88°58'46" W
10.50'

HP LIMITED
LIABILITY COMPANY
P26228

LOUISE LEE
P26233 TRACT "D"

RIVERSIDE DRIVE

PACIFIC PLACE

30'

50'

PACIFIC PLACE

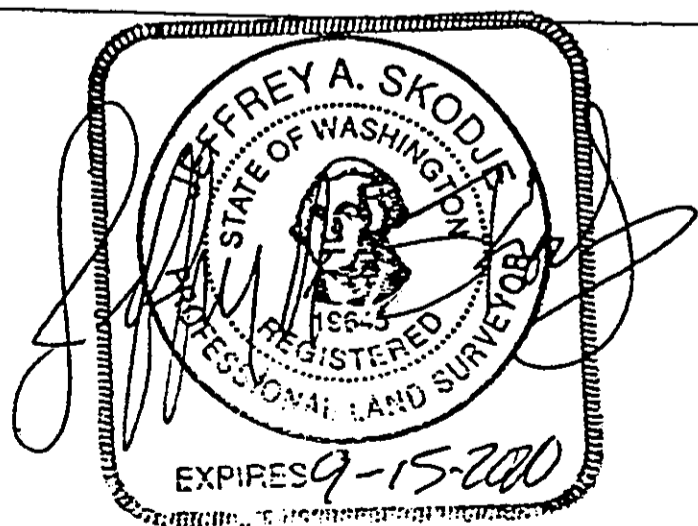

LEGEND



PROPOSED
CONSTRUCTION
EASEMENT

PROPOSED
RIGHT-OF-WAY
CONSTRUCTION EASE
ACQUISITION MAP

HP LIMITED LIABILITY COMPANY P26228

51G.DWG DJA 11-12-99
REV. BGS 5-01-00



200007140017

Kathy Hill, Skagit County Auditor