

SURVEY IN THE NW 1/4 OF SEC. 24, TWP. 35 N., RNG. 1 E., W. M.
ANACORTES, WASHINGTON

200301270117
Skagit County Auditor
1/27/2003 Page 1 of 1 1:10:22AM

LEGAL DESCRIPTION
ALL OF LOTS 8, 9, 10, AND THE WEST 10 FEET OF LOT 7, ALL IN BLOCK 230, MAP OF THE CITY OF ANACORTES, ACCORDING TO THE PLAT THEREOF RECORDED IN VOLUME 2 OF PLATS PAGES 4 THROUGH 7, RECORDS OF SKAGIT COUNTY, WASHINGTON.

TOGETHER WITH A 20 FOOT WIDE EASEMENT FOR ACCESS AND UTILITIES DESCRIBED AS FOLLOWS:
THE EAST 15 FEET OF LOT 14 TOGETHER WITH THE WEST 5 FEET OF LOT 15, ALL IN BLOCK 230, MAP OF THE CITY OF ANACORTES, ACCORDING TO THE PLAT THEREOF RECORDED IN VOLUME 2 OF PLATS PAGES 4 THROUGH 7, RECORDS OF SKAGIT COUNTY, WASHINGTON, LESS STREET RIGHT OF WAY.

- NOTES:**
1. SET RE-BAR WITH CAP # 9569 ON PREVIOUS SURVEY. AUDITOR'S # 200207120129.
 2. SET RE-BAR WITH YELLOW CAP # 9569.
 3. FOUND CONCRETE MONUMENT WITH CASE AND COVER. BASIS OF BEARINGS: N 0° 34' 46" E ALONG CL OF "D" AVE.
 4. EQUIPMENT USED: TOPCON GTS-303 5" TOTAL STATION.
 5. ERROR OF CLOSURE MEETS WASHINGTON STATE STANDARDS.
 6. THIS SURVEY DOES NOT PURPORT TO SHOW ALL EASEMENTS OR ENCUMBRANCES, OTHER THAN THOSE SHOWN ON THIS DRAWING.

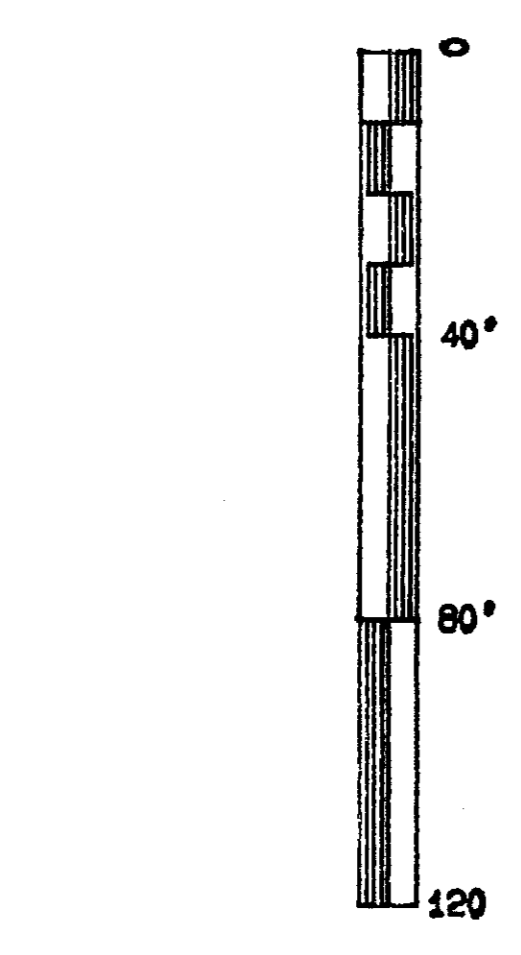
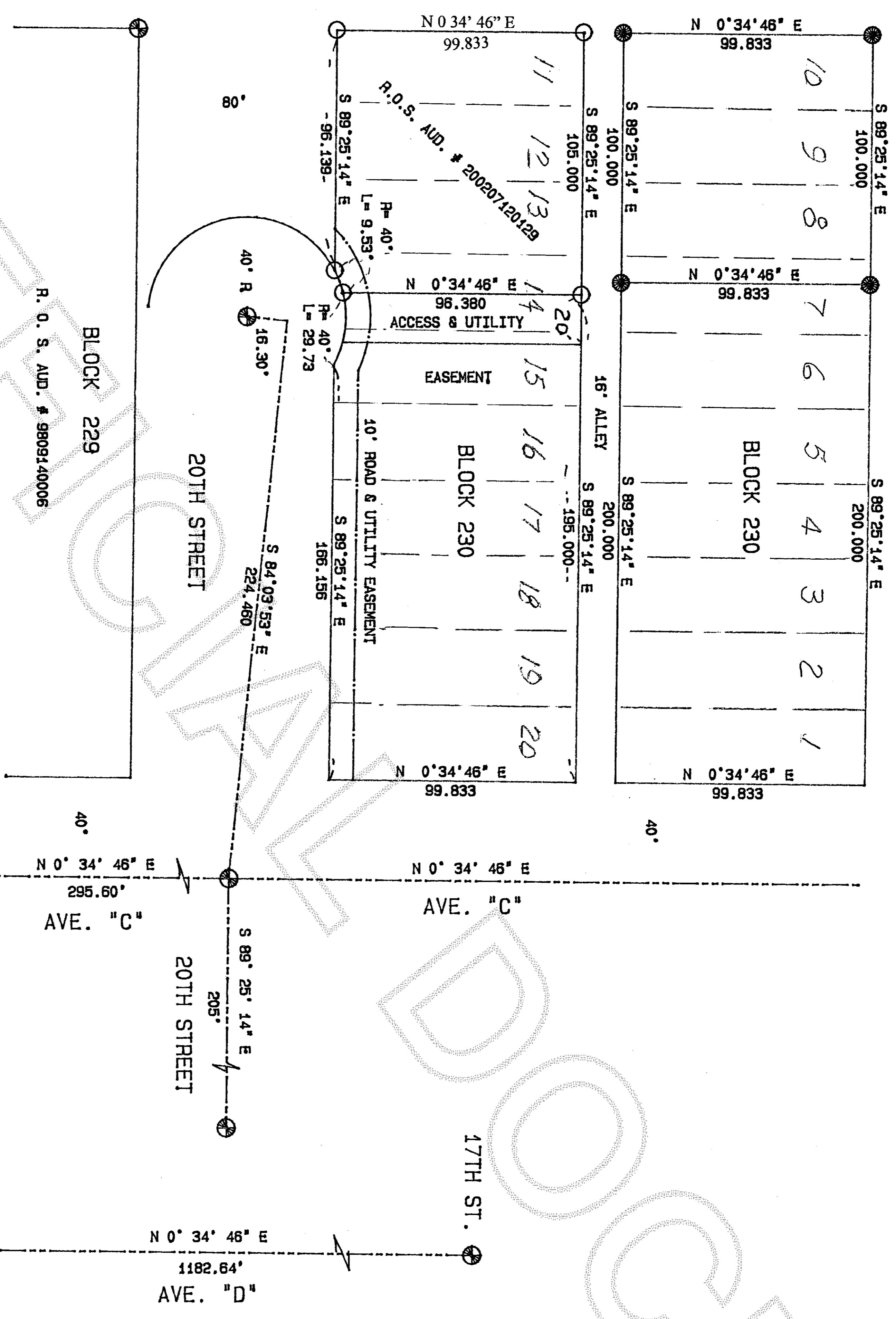

RECORDER'S CERTIFICATE
Filed for record this 27th day of Jan. 2003 at 10:22 A.M.
In book _____ of _____ at page _____ at the request of:

SURVEYORS CERTIFICATE
This map correctly represents a survey made by me or under my direction in conformance with the requirements of the Survey Recording Act at the request of: JOHN R COX & ASSOC.
In JAN 2003

CROSSMAN & ASSOC.
LAND SURVEYORS
16146 MCLEAN RD. MT. VERNON, WA.
PHONE (360) 424-7359

BOUNDARY SURVEY
FOR
JOHN R. COX & ASSOC.

Clair A. Crossman
Surveyor's Name
RECORDS OF SKAGIT CO. AUD.
Norma Hummel Weldk Deroseff
DER. AUD.

David A. Crossman
Certificate No: 9569

SCALE: 1" = 40'
DRAWN BY: SAM
DATE: 1-27-03
CHKD BY: RCH
JOB NO: 2003-04
SHEET: 1 OF 1