

**SURVEY IN THE SOUTH 1/2 OF SEC. 30, TWP. 35 N., RNG. 2 EAST, W.M.  
ANACORTES, WASHINGTON  
BOUNDARY LINE ADJUSTMENT**

200503140179  
Skagit County Auditor  
3/14/2005 Page 1 of 2 3:39PM

CONSENT  
KNOW ALL PERSONS BY THESE PRESENTS THAT WE THE UNDERSIGNED OWNERS HEREBY CERTIFY THAT THE BOUNDARY LINE ADJUSTMENT IS MADE AS OUR FREE AND VOLUNTARY ACT AND DEED.

*FRANK R. DURKSEN*  
**FRANK R. DURKSEN**  
WELLSFARGO BANK WEST, N.A.  
*John P. Decker*  
**John P. Decker, The Assoc.**  
Vice President  
WIDEBY ISLAND BANK  
*Hans A. Olsen and Vera A. Olsen*  
**Hans A. Olsen and Vera A. Olsen, Co-Trustees of the Olsen Family 1989 Revocable Trust.**

ACCEPTANCE  
THIS BOUNDARY LINE ADJUSTMENT IS HEREBY EXAMINED AND APPROVED FOR ACCEPTANCE THIS 14 DAY OF MARCH 2005  
*City Engineer*  
**CITY ENGINEER**  
*Subdivision Administrator*  
**SUBDIVISION ADMINISTRATOR**

ACKNOWLEDGEMENT  
STATE OF WASHINGTON, COUNTY OF SKAGIT  
I CERTIFY THAT I KNOW OR HAVE SATISFACTORY EVIDENCE THAT John Decker SIGNED THIS INSTRUMENT AND ACKNOWLEDGED IT TO BE HIS VOLUNTARY ACT AND FOR THE USES AND PURPOSES MENTIONED IN THE INSTRUMENT.  
DATED: 3/14/05  
SIGNATURE: *John Decker*  
TITLE: John Decker, The Assoc.  
MY APPOINTMENT EXPIRES: 4/30/07  
ACKNOWLEDGEMENT  
STATE OF WASHINGTON, COUNTY OF SKAGIT  
I CERTIFY THAT I KNOW OR HAVE SATISFACTORY EVIDENCE THAT John Decker SIGNED THIS INSTRUMENT AND ACKNOWLEDGED IT TO BE HIS VOLUNTARY ACT AND FOR THE USES AND PURPOSES MENTIONED IN THE INSTRUMENT.  
DATED: 3/14/05  
SIGNATURE: *John Decker*  
TITLE: John Decker, The Assoc.  
MY APPOINTMENT EXPIRES: 4/30/07

LEGAL DESCRIPTIONS BEFORE ADJUSTMENT:  
LOT 11 "HILLCREST TERRACE ADDITION TO ANACORTES, WASHINGTON" AS PER PLAT RECORDED IN VOLUME 7, PAGES 81 AND 82, RECORDS OF SKAGIT COUNTY, WASHINGTON.  
SITUATE IN THE CITY OF ANACORTES, COUNTY OF SKAGIT, STATE OF WASHINGTON.  
LOT 12 "HILLCREST TERRACE ADDITION TO ANACORTES, WASHINGTON" AS PER PLAT RECORDED IN VOLUME 7, PAGES 81 AND 82, RECORDS OF SKAGIT COUNTY, WASHINGTON.  
SITUATE IN THE CITY OF ANACORTES, COUNTY OF SKAGIT, STATE OF WASHINGTON.  
LEGAL DESCRIPTIONS AFTER ADJUSTMENT:  
LOT 11, IN THE PLAT OF "HILLCREST TERRACE ADDITION TO ANACORTES, WASHINGTON AS RECORDED IN VOLUME 7 OF PLATS PAGES 81 AND 82, RECORDS OF SKAGIT COUNTY, WASHINGTON, LESS THAT PORTION OF LOT 11 LYING EAST OF THE FOLLOWING DESCRIBED LINE, TOGETHER WITH THAT PORTION OF LOT 12 OF SAID PLAT LYING EAST OF SAID LINE DESCRIBED AS FOLLOWS: BEGINNING AT A POINT THAT LIES S 89.25' W 101.05 FEET ALONG THE NORTH LINES OF SAID LOTS 11 AND 12 FROM THE NORTHEAST CORNER OF LOT 11;  
THENCE S 21'44' 01" E 79.29 FEET;  
THENCE S 70'39' 45" W 8.08 FEET;  
THENCE S 21'36' 15" E 59.43 FEET TO THE SOUTH LINE OF SAID LOT 11.

ACKNOWLEDGEMENT  
STATE OF WASHINGTON, COUNTY OF SKAGIT  
I CERTIFY THAT I KNOW OR HAVE SATISFACTORY EVIDENCE THAT John Decker SIGNED THIS INSTRUMENT AND ACKNOWLEDGED IT TO BE HIS VOLUNTARY ACT AND FOR THE USES AND PURPOSES MENTIONED IN THE INSTRUMENT.  
DATED: 3/14/05  
SIGNATURE: *John Decker*  
TITLE: John Decker, The Assoc.  
MY APPOINTMENT EXPIRES: 4/30/07  
ACKNOWLEDGEMENT  
STATE OF WASHINGTON, COUNTY OF SKAGIT  
I CERTIFY THAT I KNOW OR HAVE SATISFACTORY EVIDENCE THAT John Decker SIGNED THIS INSTRUMENT AND ACKNOWLEDGED IT TO BE HIS VOLUNTARY ACT AND FOR THE USES AND PURPOSES MENTIONED IN THE INSTRUMENT.  
DATED: 3/14/05  
SIGNATURE: *John Decker*  
TITLE: John Decker, The Assoc.  
MY APPOINTMENT EXPIRES: 4/30/07



RECORDER'S CERTIFICATE  
Filed for record this 14 day of MARCH 2005 at 11:05 AM  
In book 14 of 14 at the request of:  
*Clair A. Crossman*  
**Clair A. Crossman**  
Survivor's Name  
RECORDS OF SKAGIT CO. AUD.  
*Nancy Brunner*  
**Nancy Brunner**  
DEP. AUD.

SURVEYORS CERTIFICATE  
This map correctly represents a survey made by me or under my direction in conformance with the requirements of the Survey Recording Act at the request of: FRANK DURKSEN  
In Feb, 2005  
*Clair A. Crossman*  
**Clair A. Crossman**  
Certificate No: 9569

CROSSMAN & ASSOC.  
LAND SURVEYORS  
16146 MCLEAN RD. MT. VERNON, WA.  
PHONE (360) 424-7359

BOUNDARY ADJUSTMENT  
FOR  
**FRANK DURKSEN**

SCALE: 1" = 40'	DATE: 2-26-05	JOB NO: 2005-11
DRAWN BY: SAM	CHD BY: DAC	SHEET: OF 2



**SURVEY IN THE SOUTH 1/2 SEC. 30, TWP. 35 N., RNG. 2 EAST, W.M.  
ANACORTES, WASHINGTON  
BOUNDARY LINE ADJUSTMENT**

200503140179  
Skagit County Auditor  
3/14/2005 Page 2 of 2 3:39PM

**COURSE LENGTH TABLE**

E = S 70°39' 45" W 8.08'  
 F = DELTA 29°59' 04" R = 80.00 L = 36.28  
 G = DELTA 29°21' 15" R = 80.00 L = 40.99  
 H = DELTA 29°21' 15" R = 80.00 L = 40.99  
 I = DELTA 29°21' 15" R = 80.00 L = 40.99  
 J = N 27°58' 40" W 14.13'  
 K = DELTA 3°21' 57" R = 80.00 L = 4.70

**NOTES:**

1. ● SET RE-BAR WITH YELLOW CAP # 9569.
2. ◆ SET RE-BAR WITHOUT CAP FOR LINE.
3. ○ FOUND AND ACCEPTED RE-BAR WITH CAP # 9636.
4. ⊕ FOUND MONUMENT WITH CASE AND COVER.
5. BASIS OF BEARINGS: CENTER OF SECTION LINE "NORTH".
6. EQUIPMENT USED: 5" TOPCON 303 TOTAL STATION.
7. SURVEY METHOD: STANDARD FIELD TRAVERSE.
8. ERROR OF CLOSURE MEETS WASHINGTON STATE STANDARDS.
9. THIS SURVEY DOES NOT PURPORT TO SHOW ALL EASEMENTS OR ENCUMBRANCES.

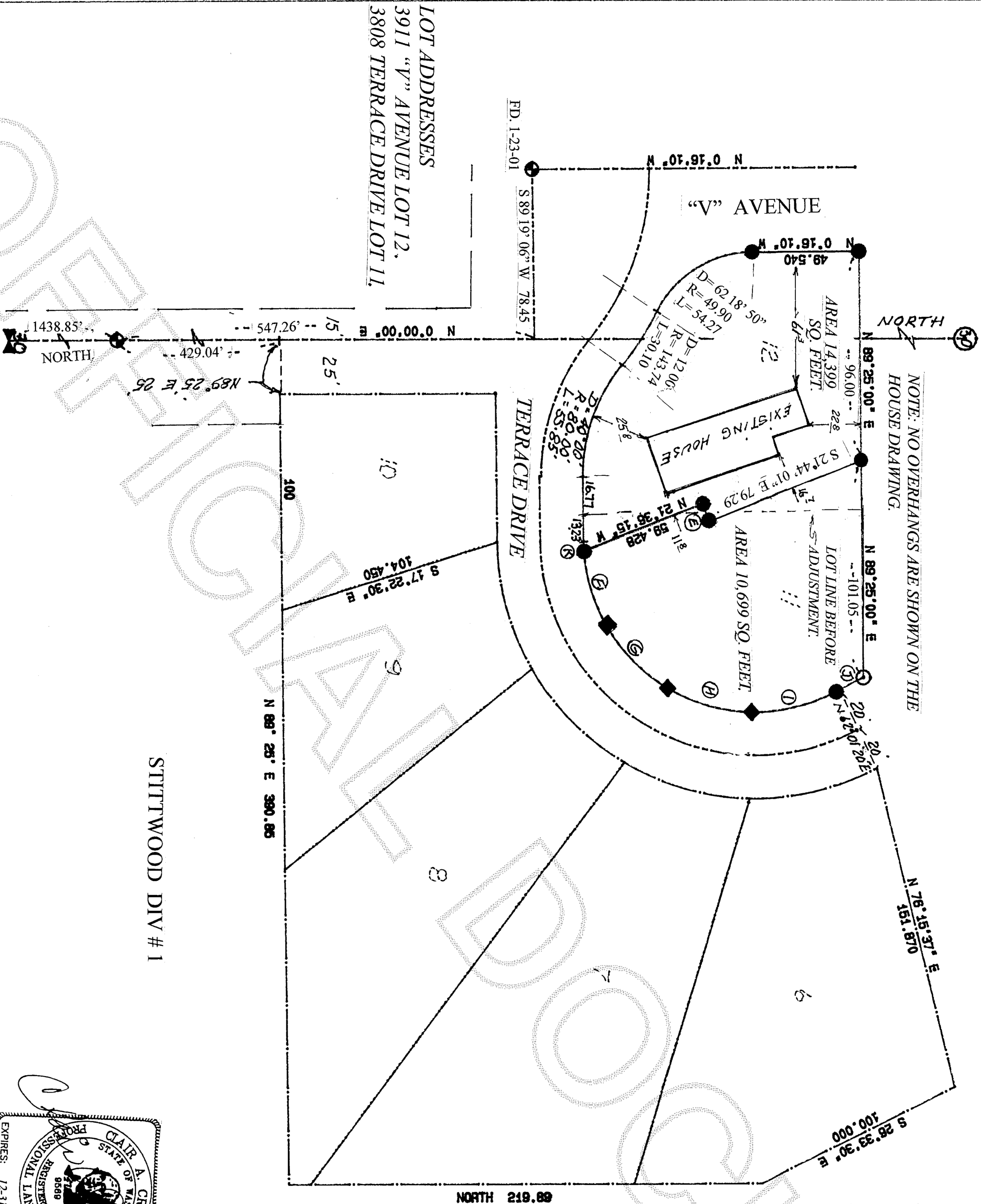

1/4 CORNER CASED  
MON. FD. 1-23-01

STITTWOOD DIV # 1

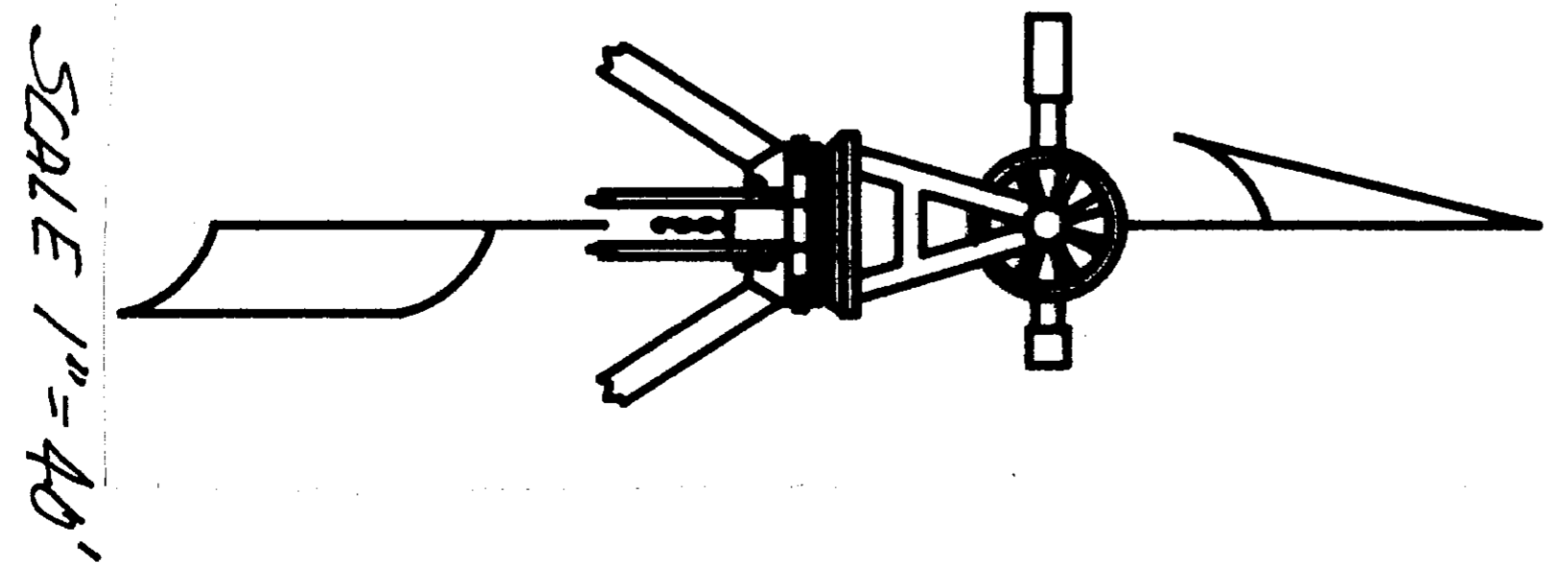

**RECORDER'S CERTIFICATE**  
 Filed for record this 14 day of March at 11:00 AM at the request of:  
Clair A. Crossman  
 SURVEYOR'S NAME  
 RECORDS OF SKAGIT CO. AND  
ANACORTES  
 AND

**SURVEYORS CERTIFICATE**  
 This map correctly represents a survey made by me or under my direction in conformance with the requirements of the Survey Recording Act at the request of: FRANK DURKSEN  
 In FEB. 2005  
Clair A. Crossman  
 Certificate No: 9569

**CROSSMAN & ASSOC.  
LAND SURVEYORS**  
 16146 MCLEAN RD. MT. VERNON, WA.  
 PHONE (360) 424-7359

**BOUNDARY ADJUSTMENT  
FOR  
FRANK DURKSEN**

SCALE	DATE	JOB NO.
1"=40'	2-26-05	2005-11
DRAWN BY:	CHKD BY:	SHEET OF:
SDH	CAC	1 2