



200610270089

Skagit County Auditor

10/27/2006 Page 1 of 15 11:37AM

**AFTER RECORDING RETURN TO:**

D. B. Johnson Construction, Inc.  
1801 Grove St., Unit B  
Marysville, WA 98270

CHICAGO TITLE COMPANY  
IQB2925

**ACCOMMODATION RECORDING**

**Document Title:**

Declaration of Easement for Drainage

Chicago Title Company has placed  
this document for recording as a  
customer courtesy and accepts no  
liability for its accuracy or validity

**Grantors:**

D. B. Johnson Construction, Inc., owner of the Lots 7, 10, 11, and 17 of the Plat of Sauk Mountain View Estates South – A Planned Residential Development – Phase 3 according to the Plat recorded under Skagit County Auditor’s File No. 200505260107, and other Grantors listed on Page 2

**Grantees:**

D. B. Johnson Construction, Inc., owner of the Lots 10, 11 and 17 of the Plat of Sauk Mountain View Estates South – A Planned Residential Development – Phase 3 according to the Plat recorded under Skagit County Auditor’s File No. 200505260107, and other Grantees listed on Page 3

**Legal Description:**

Portions of Lots 7 through 18, inclusive of the Plat of Sauk Mountain View Estates South – A Planned Residential Development – Phase 3 according to the Plat recorded under Skagit County Auditor’s File No. 200505260107, as more fully described on Pages 2 and 3;

And a portion of Tract F of Sauk Mountain View Estates South – A Planned Residential Development – Phase 2 according to the Plat recorded under Skagit County Auditor’s File No. 200401290101, as more fully described on Page 3.

**Assessor’s Property Tax Parcel/Account Numbers:**

P122921	P122922	P122923	P122924	P122925	P122927
P122928	P122929	P122930	P122931	P122932	P122933
P121332					

DECLARATION OF EASEMENT FOR DRAINAGE

KNOW ALL PEOPLE by these presents that the following owners of certain lots listed below in the Plat of Sauk Mountain View Estates South – A Planned Residential Development – Phase 3 according to the Plat recorded under Skagit County Auditor’s File No. 200505260107 located in Skagit County, Washington:

GRANTOR NAME	LOT(S) OWNED
D. B. Johnson Construction, Inc.	Lots 7, 10, 11 and 17
Sergey S. and Tatyana V. Leus	Lot 8
Laurie A. Hoff	Lot 9
Susan E. and Kelly F. Roughton	Lot 12
Jacob M. Thrumer and Cheryl A. Martin	Lot 13
Jobie Howell	Lot 14
Rebecca A. Salmon	Lot 15
Edward Herring	Lot 16
Mynor A. Penalonzo and Maria Noriega	Lot 18

and John A. Lange and Gayle Lange, owners of Tract F of Sauk Mountain View Estates South – A Planned Residential Development – Phase 2 according to the Plat recorded under Skagit County Auditor’s File Number 200401290101

do hereby grant, convey, establish and create an easement for drainage of water and the maintenance and monitoring, construction, reconstruction, repair and upkeep of the drainage equipment located in the easement area, including the cutting and removal of brush, trees and other obstructions which interfere with the use of said easement, together with the rights of ingress and egress for such purposes, over, under, along and across the portion of the following easement areas that lies within their respective lot or tract:

The Easternmost six feet of Lots 10 through 18, parallel with and adjacent to the East Line of Lots 10 through 18 of the Plat of Sauk Mountain View Estates South, Phase 3 as recorded under Skagit County Auditor’s File Number 200505260107

And

A strip of land six feet in width parallel with and adjacent to the Northwest (rear) Line of Lots 8 and 9 of the Plat of Sauk Mountain View Estates South, Phase 3 as recorded under Skagit County Auditor’s File Number 200505260107

And

The Easternmost three feet of Lot 8, parallel with and adjacent to the Eastern Line of Lot 8 of the Plat of Sauk Mountain View Estates South, Phase 3 as recorded under Skagit County Auditor’s File Number 200505260107

And



The Westernmost one foot of Lot 7, parallel with and adjacent to the Western Line of Lot 7 of the Plat of Sauk Mountain View Estates South, Phase 3 as recorded under Skagit County Auditor's File Number 200505260107

And

The Portion of Tract F of Sauk Mountain View Estates South – A Planned Residential Development – Phase 2 according to the Plat recorded under Skagit County Auditor's File Number 200401290101 described as follows: Beginning at the Southeast corner of Lot 12 thence southerly a distance of 10 feet to the Northeast corner of Lot 11 thence westerly along the North line of Lot 11 to a point six feet from said Northeast corner, thence northerly to the point of beginning.

The Grantors do hereby allow access across their respective properties to the easement area for the sole purpose of such maintenance and repairs. The owners of the properties shall be responsible for keeping the easement area within their lot clear, not blocking or filling of the easement area, and not altering the grade or flow of water across the easement area. Said easement is appurtenant to and for the benefit of the following owners of certain lots also listed below in the Plat of Sauk Mountain View Estates South – A Planned Residential Development – Phase 3 according to the Plat recorded under Skagit County Auditor's File No. 200505260107 located in Skagit County, Washington, and their heirs, future owners, successor and assigns:

<b>GRANTEE NAME</b>	<b>LOT(S) OWNED</b>
D. B. Johnson Construction, Inc.	Lot 11 and Lot 17
Sergey S. and Tatyana V. Leus	Lot 8
Laurie A. Hoff	Lot 9
Susan E. and Kelly F. Roughton	Lot 12
Jacob M. Thramer and Cheryl A. Martin	Lot 13
Jobie Howell	Lot 14
Rebecca A. Salmon	Lot 15
Edward Herring	Lot 16
Mynor A. Penalonzo and Maria Noriega	Lot 18
Rosemary Weesner and Jayme Cramer	Lot 19

Maintenance of the drainage equipment shall be the responsibility of all Grantees that benefit from the maintenance work performed.

IN WITNESS WHEREOF, the undersigned have hereunto set their hand and seal on the date indicated next to their signatures below.

*[This document signed in counterparts by the Grantors and Grantees]*



Grantor: Tract F, Sauk Mountain View Estates South, Phase 2

*John A. Lange*  
John A. Lange

8/30/06  
Date

*Gayle Lange*  
Gayle Lange

8/30/06  
Date

STATE OF WASHINGTON )  
COUNTY OF *Snohomish* )ss.

On this day personally appeared before me John A. Lange and Gayle Lange, to me known to be the individuals described in and who executed the within and foregoing instrument, and acknowledged that they signed the same as their free and voluntary act and deed for the use and purposes herein mentioned.

Dated: August 30, 2006

*Steven P. Barrett*  
Name: Steven P. Barrett  
Notary Public in and for the State of  
Washington residing at Edmonds  
My appointment expires: 9/15/07

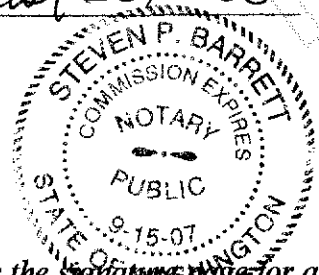

[This is the signature page for a drainage easement at Lots 7 through 18 of Sauk Mountain View Estates South, Phase 3]

SKAGIT COUNTY WASHINGTON  
REAL ESTATE EXCISE TAX

OCT 27 2006

Amount Paid  
By *[Signature]*  
Skagit Co. Treasurer  
Deputy



Grantor/Grantee: Lots 7, 10, 11, and 17  
D. B. Johnson Construction, Inc.

David B. Johnson  
David B. Johnson, President

10/14/06  
Date

STATE OF WASHINGTON )  
 ) ss.  
COUNTY OF SNOHOMISH )

On this day personally appeared before me David B. Johnson, to me known to be the President of D. B. Johnson Construction, Inc. and acknowledged to me that he was authorized to execute the foregoing instrument as such, and that said instrument was the free and voluntary act and deed of the entity referenced, for the uses and purposes therein mentioned.

DATED Oct 14, 2006

Marie K English  
Marie English, NOTARY PUBLIC in and for the  
State of Washington, residing at Marysville.  
My Commission Expires December 4, 2007.

*[This is the signature page for a drainage easement at Lots 7 through 18  
of Sauk Mountain View Estates South, Phase 3]*

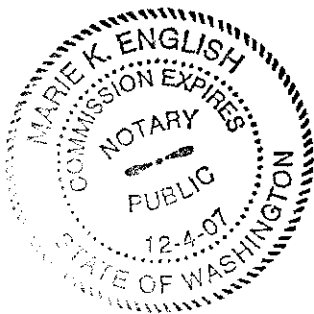

Grantor/Grantee: Lot 8

Sergey S. Leus

Date

04-13-06

Tatyana V. Leus

Date

09-13-06

STATE OF WASHINGTON )  
COUNTY OF Snohomish )ss.

On this day personally appeared before me Sergey S. Leus and Tatyana V. Leus, to me known to be the individuals described in and who executed the within and foregoing instrument, and acknowledged that they signed the same as their free and voluntary act and deed for the use and purposes herein mentioned.

Dated:

9/13/06

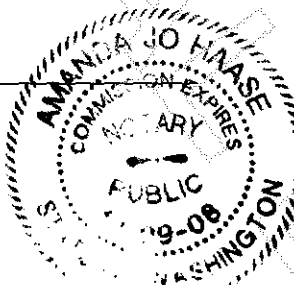

Name:

Amanda Haase

Notary Public in and for the State of

Washington residing at

Snohomish

My appointment expires:

December 9, 2008

[This is the signature page for a drainage easement at Lots 7 through 18 of Sauk Mountain View Estates South, Phase 3]



200610270089

Skagit County Auditor

Grantor/Grantee: Lot 9

Laurie A. Hoff  
Laurie A. Hoff

9/12/06  
Date

STATE OF WASHINGTON )  
COUNTY OF Snohomish )ss.

On this day personally appeared before me Laurie A. Hoff, to me known to be the individual described in and who executed the within and foregoing instrument, and acknowledged that she signed the same as her free and voluntary act and deed for the use and purposes herein mentioned.

Dated: 9/12/06

Sonya M. Caskey  
Name: Sonya M. Caskey  
Notary Public in and for the State of  
Washington residing at Marshall  
My appointment expires: 11/29/07

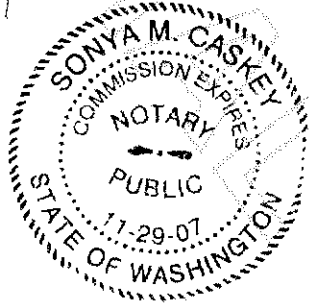

Grantor/Grantee: Lot 12

*[Handwritten Signature]*

Susan E. Roughton

9-19-06  
Date

*[Handwritten Signature]*

Kelly F. Roughton

9-19-06  
Date

STATE OF WASHINGTON )  
 )ss.  
COUNTY OF SKAGIT )

On this day personally appeared before me Susan E. Roughton and Kelly F. Roughton, to me known to be the individuals described in and who executed the within and foregoing instrument, and acknowledged that they signed the same as their free and voluntary act and deed for the use and purposes herein mentioned.

Dated: Sept 19, 2006

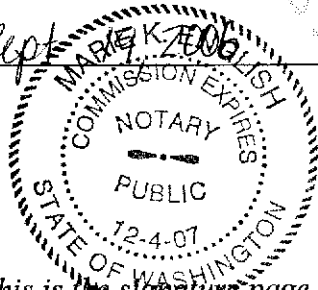

*[Handwritten Signature]*  
Name: Marie K English  
Notary Public in and for the State of  
Washington residing at Manysville  
My appointment expires: Dec 4, 2007

[This is the signature page for a drainage easement at Lots 7 through 18 of Sauk Mountain View Estates South, Phase 3]





Grantor/Grantee: Lot 13

Jacob M. Thramer  
Jacob M. Thramer

9-19-06  
Date

Cheryl A. Martin  
Cheryl A. Martin

9/19/2006  
Date

STATE OF WASHINGTON )  
 )ss.  
COUNTY OF SKAGIT )

On this day personally appeared before me Jacob M. Thramer to me known to be the individual described in and who executed the within and foregoing instrument, and acknowledged that he signed the same as his free and voluntary act and deed for the use and purposes herein mentioned.

Dated: Sept 19, 2006

Marie K English  
Name: Marie K English  
Notary Public in and for the State of  
Washington residing at Marysville  
My appointment expires: Dec 4, 2007

STATE OF WASHINGTON )  
 )ss.  
COUNTY OF SKAGIT )

On this day personally appeared before me Cheryl A. Martin to me known to be the individual described in and who executed the within and foregoing instrument, and acknowledged that she signed the same as her free and voluntary act and deed for the use and purposes herein mentioned.

Dated: Sept 19, 2006

Marie K English  
Name: Marie K English  
Notary Public in and for the State of  
Washington residing at Marysville  
My appointment expires: Dec 4, 2007



This is the signature page for a drainage easement at Lots 7 through 18 of Skagit Mountain View Estates South, Phase 3]



Grantor/Grantee: Lot 14

*Jobie Howell*

Jobie Howell

19 SEPT 2006

Date

STATE OF WASHINGTON )  
 )ss.  
COUNTY OF SKAGIT )

On this day personally appeared before me Jobie Howell, to me known to be the individual described in and who executed the within and foregoing instrument, and acknowledged that she signed the same as her free and voluntary act and deed for the use and purposes herein mentioned.

Dated: Sept 19, 2006

*Marie K English*  
Name: Marie K English  
Notary Public in and for the State of  
Washington residing at Marysville  
My appointment expires: Dec 4, 2007

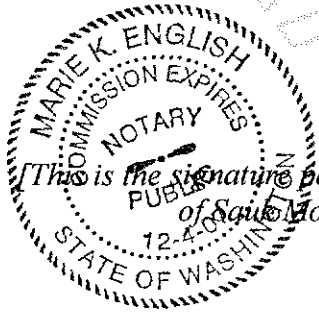

[This is the signature page for a drainage easement at Lots 7 through 18 of South Mountain View Estates South, Phase 3]





Grantor/Grantee: Lot 16

Edward Herring  
Edward Herring

9-11-06  
Date

STATE OF WASHINGTON )  
 )ss.  
COUNTY OF SKAGIT )

On this day personally appeared before me Edward Herring, to me known to be the individual described in and who executed the within and foregoing instrument, and acknowledged that he signed the same as his free and voluntary act and deed for the use and purposes herein mentioned.

Dated: September 11, 2006

Stephanie F White  
Name: STEPHANIE F. WHITE  
Notary Public in and for the State of  
Washington residing at Sadro Woolley  
My appointment expires: Oct 30, 2006

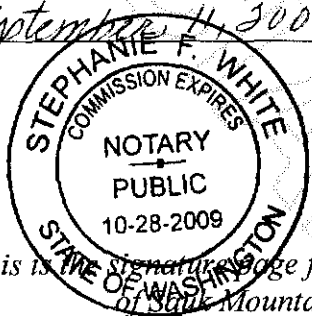

[This is the signature page for a drainage easement at Lots 7 through 18 of Sadro Mountain View Estates South, Phase 3]



Grantor/Grantee: Lot 18

Mynor A. Penalonzo  
Mynor A. Penalonzo

9 Oct 2006  
Date

Maria Noriega  
Maria Noriega

10/9/06  
Date

STATE OF WASHINGTON )  
COUNTY OF Skagit )ss.

On this day personally appeared before me Mynor A. Penalonzo to me known to be the individual described in and who executed the within and foregoing instrument, and acknowledged that he signed the same as his free and voluntary act and deed for the use and purposes herein mentioned.

Dated: 10/9/06

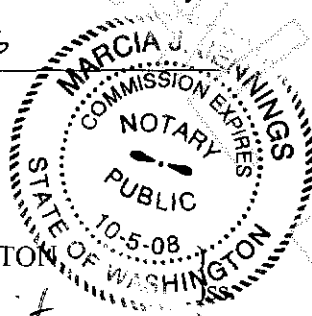

Marcia J. Jennings  
Name: Marcia J. Jennings  
Notary Public in and for the State of  
Washington residing at Sedro Woolley  
My appointment expires: 10/5/2008

STATE OF WASHINGTON )  
COUNTY OF Skagit )

On this day personally appeared before me Maria Noriega to me known to be the individual described in and who executed the within and foregoing instrument, and acknowledged that she signed the same as her free and voluntary act and deed for the use and purposes herein mentioned.

Dated: 10/9/06

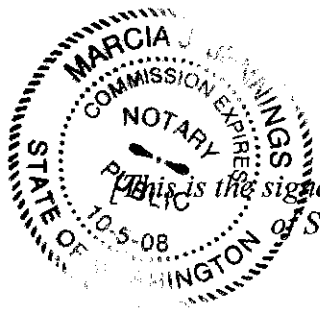

Marcia J. Jennings  
Name: Marcia J. Jennings  
Notary Public in and for the State of  
Washington residing at Sedro Woolley  
My appointment expires: 10/5/2008

This is the signature page for a drainage easement at Lots 7 through 18 of Sauk Mountain View Estates South, Phase 3]



Grantee: Lot 19

Rosemary Weesner  
Rosemary Weesner

10-2-06  
Date

Jayne Cramer  
Jayne Cramer

9-28-06  
Date

STATE OF WASHINGTON )  
 )ss.  
COUNTY OF Snohomish )

On this day personally appeared before me Rosemary Weesner to me known to be the individual described in and who executed the within and foregoing instrument, and acknowledged that she signed the same as her free and voluntary act and deed for the use and purposes herein mentioned.

Dated: 10.2.06

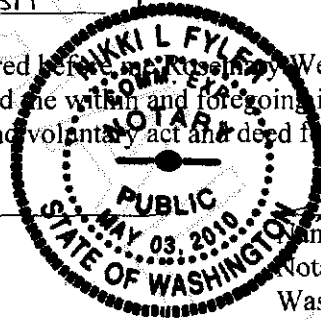

Nikki L Fyle  
Name: NIKKI FYLE  
Notary Public in and for the State of WA  
Washington residing at Manville  
My appointment expires: May 3, 2010

STATE OF WASHINGTON )  
 )ss.  
COUNTY OF Snohomish )

On this day personally appeared before me Jayne Cramer to me known to be the individual described in and who executed the within and foregoing instrument, and acknowledged that (s)he signed the same as his/her free and voluntary act and deed for the use and purposes herein mentioned.

Dated: 9.28.06

Kristen Buchanan  
Name: Kristen Buchanan  
Notary Public in and for the State of WA  
Washington residing at Manville  
My appointment expires: 01-14-10



[This is the signature page for a drainage easement at Lots 7 through 18 of Skuk Mountain View Estates South, Phase 3]

14 15  
Page 14 of 12 g



UNOFFICIAL

# Exhibit A

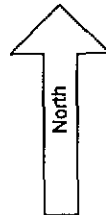

1" = 60'

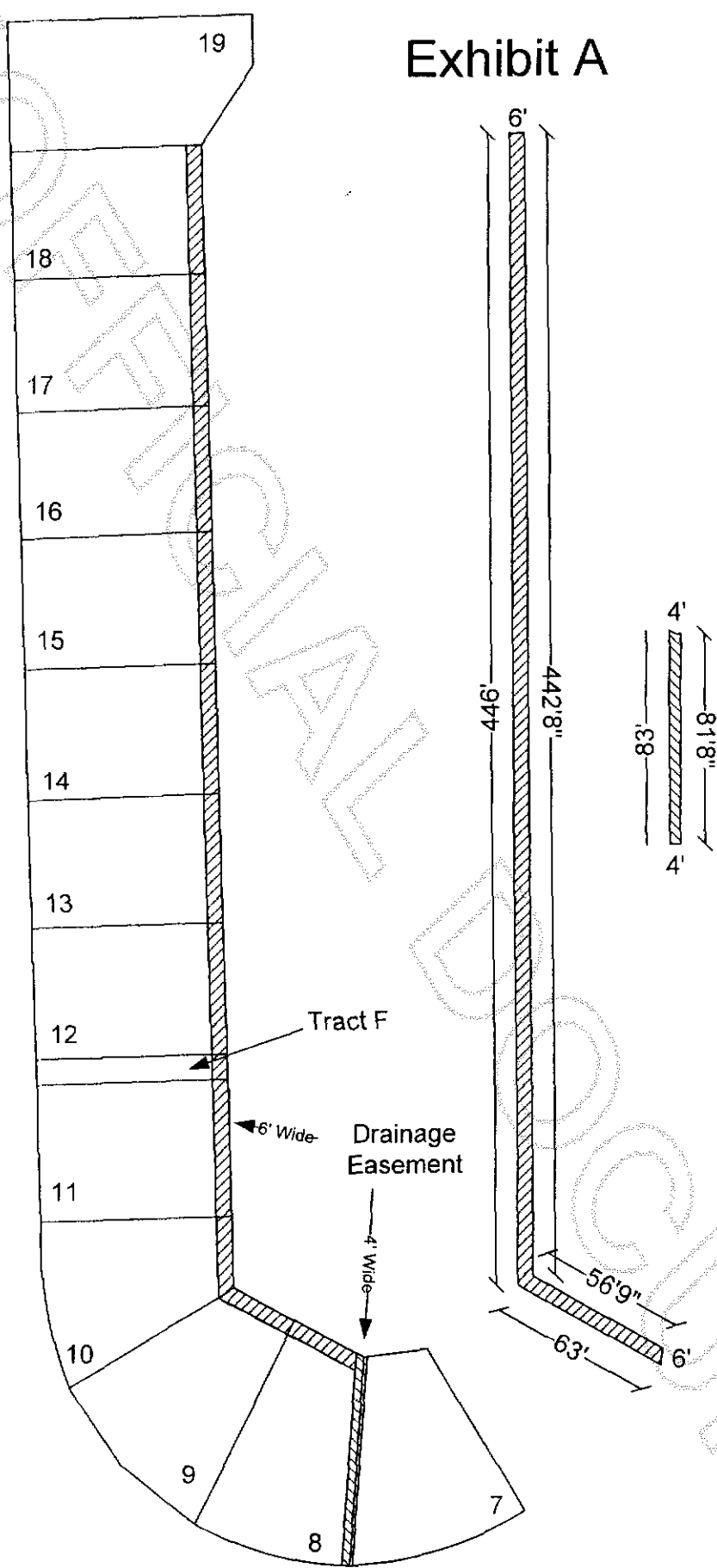

200610270089  
Skagit County Auditor

10/27/2006 Page 15 of 15 11:37AM

UNOFFICIAL